

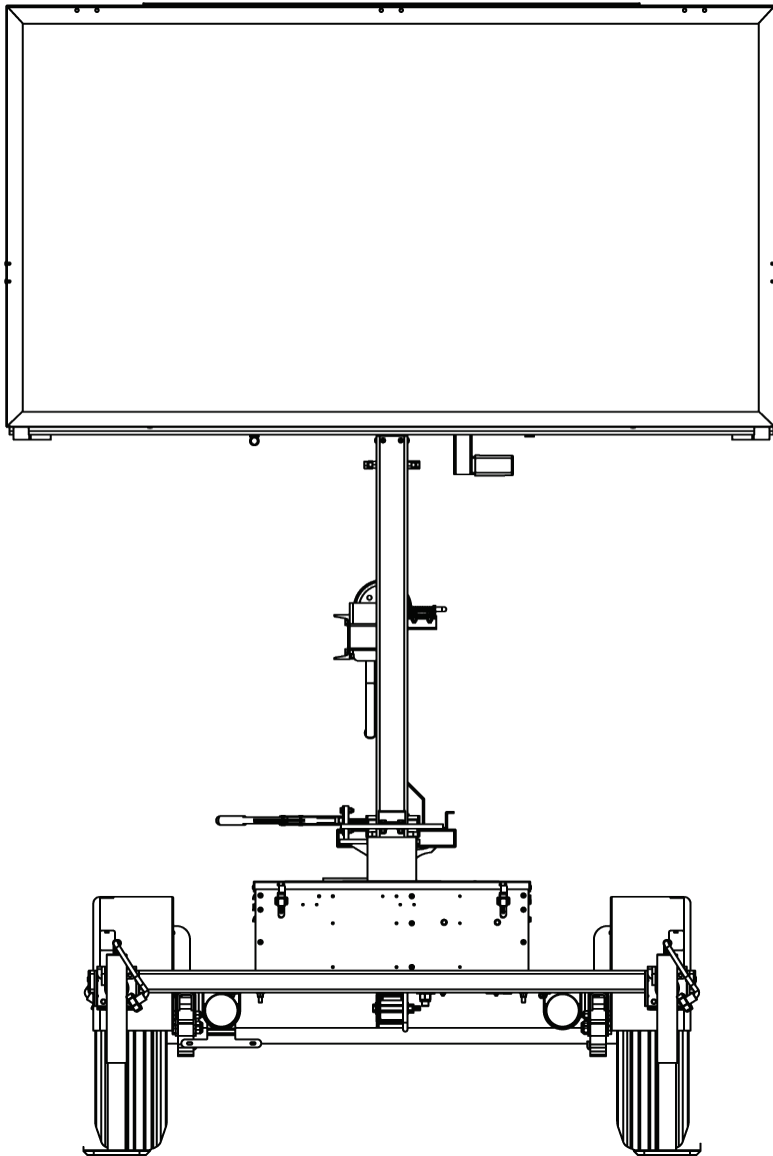

WSD-1007
01 2014

5-COLOR METRO™ MESSAGE SIGN

MODEL WVTMM-L-5C
PRODUCT SPECIFICATIONS | JANUARY 2014



1. DESCRIPTION

- 1.1. Description Wanco® designed the Metro™ message sign for use in metropolitan areas and wherever trailer size is a concern. The Metro sign provides the visibility and legibility of other Wanco message signs, but with a smaller footprint.
- The color Metro message sign provides information to the public on a five-color LED display that can present text, graphics, or a combination of both. The color display uses state-of-the-art technology to achieve excellent visibility with the least power consumption of any available portable color message sign. This sign is portable and self-powered, requiring no permanent installation or wiring. Its compact design makes it highly maneuverable and easy to deploy. The trailer can be towed by most vehicles.
- The Metro sign has a self-contained onboard computer and a touchscreen controller, making a laptop or external controller unnecessary. A laptop can be connected if desired. The sign comes configured with preprogrammed standard messages, and users can create custom messages easily.
- For optimal positioning, the message sign display panel rotates independent of the trailer and its height is fully adjustable. Jack-legs provide stability.
- Power is provided by maintenance-free batteries, which are charged by an automated solar charging system.
- 1.2. Model WVTMM-L-5C Metro matrix message sign with five-color display

2. FEATURES

- 2.1. Message design
- Message Graphics computer software included for creating custom messages
 - Create, import and edit graphics
 - Add and format text
 - Export messages to sign and save files for copying and editing
- 2.2. Setup
- Heavy-duty hand-winch allows one person to easily raise and lower the sign display
 - Tower rotates 360 degrees for optimal positioning
 - Single disk brake holds tower in place during operation, while a cradle supports and holds board in travel position
- 2.3. Operation
- Five-color, full-matrix display for text and graphics
 - Self-contained onboard computer
 - Full-color touchscreen controller with high-resolution display
 - User-supplied laptop with Wanco software is optional
 - Multi-level password protection restricts access to control software
 - Preprogrammed text messages, symbols and graphics
 - Internal clock facilitates built-in schedule programming
 - Multiple alphanumeric fonts

- 2.4. Power system
- Energy-efficient operation results in long run times
 - Solar panels charge batteries automatically without intervention
 - System shuts down solar-panel charging system when batteries are fully charged, preventing damage
 - Power system allows battery charging with solar panels or commercial power
 - Cooling fan protects battery charger from overheating
 - Battery box can be locked to prevent unauthorized access
- 2.5. Maintenance
- Maintenance-free batteries
 - Individual display modules can be replaced easily
 - Standard trailer tires
 - Heavy-duty bolt-on steel fenders can be replaced if damaged
- 2.6. Application
- Common uses for the Metro sign include urban areas where a sidewalk is the only place to put a message sign, congested streets where a larger sign might impede traffic, and anywhere a larger sign is not practical. Common applications for color signs include:
- Special events
 - Traffic calming
 - Emergency response
 - Public notices
 - Corporate functions

3. DISPLAY

3.1. Cabinet

- 3.1.1. Description
- Weather-resistant cabinet contains display modules and related electronics. Hinged door with full-size display window protects electronics and provides access for maintenance. Clasps hold door closed during operation and the door can be locked with user-supplied padlock.
- 3.1.2. Size
- 89" x 49" x 6" (226 x 124 x 15cm) W x H x D
- 3.1.3. Material
- Aluminum sheet, 5052-H32, 0.062" (1.575mm) thick
- 3.1.4. Construction
- Panels are riveted together, with internal ribs to add lateral strength
- 3.1.5. Door
- Cabinet door is aluminum extruded frame with sheet metal corner brackets. Stainless steel butt hinges are bolted to top of cabinet and door.
- Window is anti-glare Lexan® solar-grade polycarbonate, 0.150" (3.81mm) thick. Bulb-type weather seal ensures tight fit and seal between window and door frame.
- When sign is in stored position, door fully opens to service the sign cabinet interior. Telescoping prop-slides, one on each side of the cabinet, hold door open.

- 3.1.6. Finish Cabinet and door are coated with oven-baked, powder-coat finish to ensure durability and corrosion protection. Cabinet is coated white on the outside, flat black on the inside; door is flat black. Assemblies are high-pressure phosphate-washed prior to finish coat.
- 3.1.7. Wiring Wiring service loop from computer box to display cabinet is routed inside liquid-tight loom and P-clamped to trailer frame. Service loop length is designed to allow sign rotation. All wiring connectors and procedures are per CSA standards.
- 3.1.8. Storage When lowered for storage and transport, the display cabinet rests in a support cradle, parallel to the trailer length, no locking pins required
- 3.2. Display matrix
- 3.2.1. Description The display matrix is comprised of a series of display modules laid out in a grid across the inside of the display cabinet. Each module has a matrix of LEDs installed on its face, which light up to show a portion of the configured message. Each module features the necessary electronics and coatings to ensure outstanding performance and durability.
- 3.2.2. Display modules
- | | |
|------------------|------------------------------------------------------------------------------------------------------------------------------------------------------------------------------------------------------------------------------------------------------------------------------------------------------------------------------------------------|
| Modular design | Allows any display module to be installed in any position in the matrix without repositioning DIP switches |
| Wiring | Modules have quick-connect electrical connectors for easy servicing. All wiring terminates at a single terminal strip inside the display cabinet. |
| Replacement | Each module can be exchanged in less than two minutes. The only tool needed is a 5/16-inch nut driver socket or slotted screwdriver

After a new module is installed, a one-step initialization process causes each module to sense its position in the full-matrix display. Initialization is accomplished using the sign's controller. |
| Firmware | A program chip is socket replaceable for easy firmware upgrades |
| Size | 16.0" (40.6cm) wide by 13.13" (33.3cm) high, nominal |
| Material | FR4 glass-reinforced epoxy laminate, double-sided, black solder mask with white silkscreen

Board thickness, 0.094" (2.388mm)

Copper size, 1 oz. (28.4g) |
| Coating | 5-mil, military-spec, low-VOC, silicone conformal coating (Dow Corning 1-2577) provides long-term protection against moisture and other atmospheric contaminants, resists corrosion and shorts due to high humidity |
| Vibration mounts | All display modules are mounted on rubber vibration-isolation mounts, decreasing risk of physical shock during transport and isolating characters from chassis ground |

Temperature limits -40 to 176°F (-40 to 80°C)

Humidity limits Conformal coating rated to 95% relative humidity

3.2.3. Pixels

A cluster of 15 LEDs form a “pixel”

Each pixel has 3 LEDs of each color (amber, blue, green, red, white):

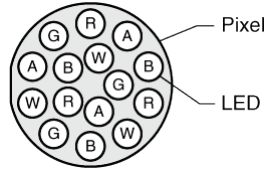

Pixel size 1.0625" (27mm) diameter

Full matrix 50 pixels wide by 24 pixels high, 1200 pixels total

Display module 10 pixels wide by 8 high, 80 pixels total

Pixel pitch 42mm, horizontal and vertical

3.2.4. LEDs

Technology AllInGaP II (aluminum indium gallium phosphide) technology, T-1¼ size, through-hole auto-insertion

Color range	Amber	589.5 to 592.0 nm
	Blue	470 to 475 nm
	Green	525 to 530 nm
	Red	620 to 625 nm
	White	Not applicable

Current 10 mA peak-pulsed forward current

Temperature limits Operating temperature, -40 to 212°F (-40 to 100°C)

3.2.5. LED shields

Each individual LED is shielded from the other LEDs in each pixel, preventing “phantom” lighting of unlit LEDs by lit LEDs, reducing reflected light, improving angularity, and enhancing the clarity of the display

3.2.6. Viewing angle

Total viewing area, 25 degrees nominal

3.2.7. Brightness

Factory preset for optimal viewing and power consumption

3.2.8. Auto dimming

Two photocells detect ambient light on the message sign; the message sign computer adjusts the brightness of the LEDs accordingly, dimming display brightness in darkness, increasing to full brightness in daylight

Photocells are mounted inside the sign cabinet, one facing rear and one facing front

3.2.9. Software design	Driver	LEDs controlled through 10mA pulse-width modulation design
	Addressing	Each display module address is selected through a software command; no DIP switches are used. The address does not change until reprogrammed, preventing the message from shifting due to an individual module failure.
	Pixel test	Each module is equipped with individual pixel failure notification
3.2.10. Fonts	12 fonts (for samples, see Exhibit A)	
	Default size	5 x 7 pixels (W x H), 7.68" x 10.98" (19.5 x 27.9cm) Character spacing for standard three line message, 3" (7.6cm) between lines, 3" (7.6cm) between letters Maximum 3 lines of 8 letters per line
	Smallest size	4 x 5 pixels (W x H)
	Largest size	11 x 23 pixels (W x H)
	Other sizes	See Exhibit A

4. CONTROL SYSTEM

4.1. Computer

4.1.1. Description Self-contained onboard computer, located inside battery box, comprises main motherboard and power control board, controls sign functions

4.1.2. Housing

Material 18ga steel

Size 11.5" x 9.50" x 3.75" (29.1 x 24.1 x 9.5cm) W x H x D

Finish Oven-baked, flat-black, powder-coat finish to ensure durability and corrosion protection; high-pressure phosphate-washed prior to finish coat. All parts powder-coated before assembly.

Mounting Welded mounting flanges; bolted to bottom of battery box

Internal access Top panel is bolted in place and can be removed for access to internal components

4.1.3. Temperature limits -40 to 176°F (-40 to 80°C)

4.1.4. Wiring

One CPC connector for wiring cable from message sign

One CPC connector for wiring cable from power supply

4.1.5.	Ports	One USB power/communication port for connection to controller One Ethernet communications port for optional connection to laptop computer or modem Two DB9 serial ports for connection to auxiliary devices						
4.2.	Controller							
4.2.1.	Description	Touchscreen interface, connected to computer for programming and running sign display. No laptop computer required, but a laptop with Wanco software can be connected in place of controller if desired.						
4.2.2.	Touchscreen	<table><tr><td>Display</td><td>Full color, backlit, 7-inch display 800 x 480 pixels Display automatically shuts off after 10 minutes of inactivity</td></tr><tr><td>Interface</td><td>Menu-based structure, accessed with virtual buttons on the touchscreen display, provides access to all sign functions including programming messages Virtual keyboard appears when required for text entry Multi-level password protection restricts access Day/night virtual button, changes contrast for use in bright or dim lighting conditions Message on sign is always shown while interface is active</td></tr></table>	Display	Full color, backlit, 7-inch display 800 x 480 pixels Display automatically shuts off after 10 minutes of inactivity	Interface	Menu-based structure, accessed with virtual buttons on the touchscreen display, provides access to all sign functions including programming messages Virtual keyboard appears when required for text entry Multi-level password protection restricts access Day/night virtual button, changes contrast for use in bright or dim lighting conditions Message on sign is always shown while interface is active		
Display	Full color, backlit, 7-inch display 800 x 480 pixels Display automatically shuts off after 10 minutes of inactivity							
Interface	Menu-based structure, accessed with virtual buttons on the touchscreen display, provides access to all sign functions including programming messages Virtual keyboard appears when required for text entry Multi-level password protection restricts access Day/night virtual button, changes contrast for use in bright or dim lighting conditions Message on sign is always shown while interface is active							
4.2.3.	Housing	<table><tr><td>Backplate</td><td>Internal components mounted to aluminum backplate for rigidity</td></tr><tr><td>Cover</td><td>Injection-molded PC/ABS</td></tr><tr><td>Size</td><td>8.0" x 5.5" x 1.6" (20.3 x 14.0 x 4.1cm) W x H x D</td></tr></table>	Backplate	Internal components mounted to aluminum backplate for rigidity	Cover	Injection-molded PC/ABS	Size	8.0" x 5.5" x 1.6" (20.3 x 14.0 x 4.1cm) W x H x D
Backplate	Internal components mounted to aluminum backplate for rigidity							
Cover	Injection-molded PC/ABS							
Size	8.0" x 5.5" x 1.6" (20.3 x 14.0 x 4.1cm) W x H x D							
4.2.4.	Storage and removal	Stored in cradle inside battery box. Can be lifted out of cradle and is designed to be handheld. Can be disconnected and removed.						
4.2.5.	Wiring	Connected to computer with USB cable						
4.2.6.	Power	Power supplied from computer Push-button on bottom of housing provides manual on/off control and interface activation after timeout Electronics automatically shut down after 20 minutes of inactivity						
4.2.7.	Weight	1.6 lbs. (0.73kg)						
4.2.8.	Temperature limits	-4 to 158°F (-20 to 70°C)						

- 4.3. PC boards
 - 4.3.1. Data ports 5 serial ports; 2 USB ports, 1 Ethernet port
 - 4.3.2. Coating 100% coated with military-spec, low-VOC, silicone conformal coating to provide long-term protection against moisture and other atmospheric contaminants. Resists corrosion and shorts due to high humidity.
 - 4.3.3. Temperature limits -4 to 176°F (-20 to 80°C)
 - 4.3.4. Humidity limits Conformal coating rated to 95% relative humidity
- 4.4. Controller software
 - 4.4.1. Standards Fully NTCIP-compliant
 - 4.4.2. Security Three levels of password protection
 - 4.4.3. Message programming Instant access to program new messages
Extremely easy to program
 - 4.4.4. Message types
 - Quick-messages Easy quick-message activation
 - Permanent Over 90 preprogrammed permanent messages, including arrows and FHWA standards
 - Changeable 250 changeable messages stored in NV flash
 - Temporary 10 temporary or volatile messages, for ITS systems
 - Blank Easy sign blanking/power off
 - 4.4.5. Interface display WYSIWYG (What You See Is What You Get) while programming
 - 4.4.6. Text alignment Selectable: left, center, or right; and top, middle, or bottom
 - 4.4.7. Fonts Selectable: see Exhibit A
 - 4.4.8. Blinking
 - Each character can individually blink
 - Individual lines of a multi-line message can blink
 - The entire message can blink
 - Adjustable timing and duty cycle
 - 4.4.9. Message pages Maximum 10 sequential “pages” per message, sequencing speed from 0.1 to 25.5 sec.
 - 4.4.10. Scheduling Real-time clock and calendar with DST control

- 4.4.11. Arrow board functions Sign can display any of the following 12 full-size arrow functions
- | | |
|---------------|-------------------------------------------------------------------------------------------------------------------------------------------------------------------------------------------------------------------------------------------------------------------------------------------------------|
| Modes | Flashing left or right arrow
Flashing double arrow
Flashing four-corner warning
Flashing caution-bar warning
Sequencing left or right arrow
Sequencing left or right stem arrow
Sequencing left or right chevron arrows
Alternating diamonds

(for samples, see Exhibit B) |
| Bold graphics | Each arrow and bar is 5 pixels wide |
- 4.4.12. Configuration Menus provide access to all message sign configuration settings
- 4.4.13. Troubleshooting Status and diagnostic menus provide message sign information to assist in troubleshooting

5. GRAPHICS SOFTWARE

- 5.1. Description Computer software provides the tools necessary for creating custom messages. Create new messages in five colors. Create messages from scratch using text, graphics or a combination of both; or edit previously created messages. Import graphic images, such as logos and digital photos.
- 5.2. System requirements Any computer running Microsoft® Windows® XP, Vista, 7, or 8
- 5.3. File formats Save files in proprietary format that the program can open for editing
Save objects created in a message for re-use when creating new messages
Export files in the NTCIP MULTI format for uploading to a message sign
Import MULTI files for bitmap editing
- 5.4. Message transfer Transfer messages to sign directly from the graphics program when the computer is connected to the sign via a wireless modem or a wired Ethernet connection
Transfer messages to the sign using the Wanco NTCIP Central software after export in the MULTI file format
Transfer messages to the sign using a USB flash drive after export in the MULTI file format

6. TRAILER

- 6.1. Frame All welded structural steel
- 6.2. Fenders Round full wheel coverage fenders with inner splash panel on each fender. Fenders are bolted to the trailer frame.
Material: 16ga steel
- 6.3. Tie-downs Three tie-downs: one on each front corner of frame, one centered on rear of frame
- 6.4. Finish Frame is coated with oven-baked, safety-orange powder-coat finish to ensure durability and corrosion protection. Assemblies are run through a five-stage, high-pressure phosphate-wash prior to finish coat.
See "Options and Optional Equipment" for color options.
- 6.5. Axle assembly 2000 lb. (907kg) capacity, 5 on 4.5" B.C. idler hub
- 6.6. Springs Double-eye leaf springs
- 6.7. Tires ST205/75D15 steel-belted trailer tires, load rating B
- 6.8. Drawbar
- 6.8.1. Construction Telescopes inside receiver sleeve welded under trailer frame. Removable for shipping and for added theft protection if needed. Secures with two 1/2-inch (12mm) diameter bolts.
- 6.8.2. Material Square tubing, 3" x 3/16" wall (7.62cm x 0.476cm wall)
- 6.8.3. Jack Top-wind swivel, 800-lb. (363kg) capacity with caster wheel to make moving trailer easier
- 6.8.4. Tow hitch Standard 2-inch ball coupler tow-hitch, SAE Class 2, 3500-lb. (1588kg) capacity. Bolts to drawbar, removable and replaceable.
See "Options and Optional Equipment" for tow-hitch options.
- 6.8.5. Tow chains Two high-test proof coil chain assemblies, with "latching" S-hooks for towing. Chains attached to drawbar with quick connectors.
Material diameter 0.406" (10.3mm)
Working load limit 5400 lbs. (2450kg)
Breaking force 16,200 lbs. (72kN)
- 6.9. Stabilizer jacks Four swivel jacks, each with 2000-lb. (907kg) capacity, mounted on corners of trailer frame
- 6.10. Wind resistance In the deployed position, the maximum sustainable wind speed before overturning, when supported by the standard jack stands with tires off the ground, is 50 mph (80km/h)

- 6.11. Wiring
 - 6.11.1. Description Wiring to connect tow vehicle and trailer for trailer taillights is installed inside drawbar, with pigtailed and connectors at both ends; no crimping required
 - 6.11.2. Trailer plug A sealed, molded, 4-square connector plugs into harness under trailer
 - 6.11.3. Tow-vehicle plug Two-piece assembly with 4-flat molded connector on harness plugs into tow vehicle
Meets SAE J1239
See "Options and Optional Equipment" for tow-vehicle plug options
 - 6.11.4. Protection All trailer wiring encased in UV protective loom, and attached with P-clamp riveted to trailer frame; no exposed wires
- 6.12. Taillights
 - 6.12.1. Type Two oval-shaped, sealed, combination stop, turn and taillights
 - 6.12.2. Location Mounted to top of trailer deck behind fenders
 - 6.12.3. Mounting No screws used for mounting; bracket is welded to trailer frame; each light held in place and sealed with snap-in rubber grommet
- 6.13. License plate A lighted license plate light holder is mounted to rear trailer frame
- 6.14. Reflectors Sides of trailer have amber reflectors near front and red reflectors near rear
See "Options and Optional Equipment" for reflective tape
- 6.15. Tower assembly
 - 6.15.1. Function Sign cabinet is raised and lowered on a telescoping tower
 - 6.15.2. Tower construction Two sections of square steel tubing with the inner section telescoping inside the outer section. The inner section is zinc plated to prevent corrosion.
Nylon guide blocks keep the sections tight, eliminating the need for greasing the tower and preventing dirt from building up on the inner tower section. Dirt would cause performance problems and maintenance issues.
 - 6.15.3. Swivel base A steel tubular weldment is bolted to the trailer frame. The outer tower section rotates on a thrust bearing and washers inside the swivel base, reducing rotating friction.
 - 6.15.4. Height At fully deployed height, 84" (213cm) from ground to bottom of display cabinet
 - 6.15.5. Height lock Spring-loaded locking pin prevents tower from falling if the winch or cable were to fail. Also locks tower when fully lowered into travel position.

- 6.15.6. Winch assembly
 - Function Hand-operated winch raises and lowers sign cabinet
 - Capacity 1500 lbs. (680kg)
 - Brake Safety friction-brake prevents display cabinet from falling if operator loses grip on winch handle
 - Cable 1/4" (6.35mm) diameter galvanized aircraft cable
- 6.15.7. Rotation Sign rotates by hand, pivoting 360 degrees on tower
- 6.15.8. Rotation lock Sign rotation is locked with an adjustable lever that operates a mechanical friction caliper and disk brake. The ½-inch thick, round, zinc-plated brake disk is bolted to the outer tower section.
- 6.15.9. Sight tube A sight tube for aiming the message sign in desired direction is mounted to the underside of the display cabinet frame

7. POWER SYSTEM

- 7.1. Description Electronics powered by batteries, which are charged automatically with integrated solar charging system
- 7.2. Battery box
 - 7.2.1. Function Holds batteries and remote charger
See "Options and Optional Equipment" for heavy-duty secure battery box
 - 7.2.2. Construction Riveted all-steel construction
All parts powder-coated before assembly
Divider panel inside box separates batteries from electronics
Louvers provide ventilation
Latches keep cover closed and can accept user-supplied padlocks
 - 7.2.3. Location Centered over axle on between fenders, bolted to trailer frame
- 7.3. Batteries
 - 7.3.1. Description Three 4D AGM 12Vdc batteries
See "Options and Optional Equipment" for battery options
 - 7.3.2. Features 100% maintenance-free
Sealed and spill-proof
Faster recharge and greater freeze resistance than conventional batteries
Contains less lead than conventional batteries
 - 7.3.3. Voltage 12Vdc each

7.3.4.	Weight	Approx. 160 lbs. (72kg) each
7.3.5.	Capacity	600 Ah total
7.4.	Remote charger	
7.5.	Function	Plugs into a standard commercial power source to recharge batteries if battery voltage drops due to lack of sun for automated solar charging system
7.5.1.	Type	12-volt battery charger
7.5.2.	Location	Inside battery box, mounted to divider panel on opposite side from batteries
7.5.3.	Output capacity	45A
7.5.4.	Output voltage	13.4Vdc @ full load 13.6Vdc standard float voltage 14.2Vdc with dual-voltage jack installed
7.5.5.	Input voltage	108 to 132Vac, standard three-prong plug
7.5.6.	Input frequency	50 to 60 Hz
7.5.7.	Cooling	Automatic fan cooling
7.6.	Solar	
7.6.1.	Panels	Two high-efficiency multi-crystal photovoltaic solar modules
7.6.2.	Location	Behind message sign, over tower. Solar panel array lies flat, rises and rotates with message sign. No shadowing effect on any trailer component.
7.6.3.	Power output	130W per solar panel 260W total
7.6.4.	Current	9.5A max. system current 10.3A open short-circuit current
7.6.5.	Voltage	17.9Vdc max. 21.8Vdc open short-circuit voltage
7.6.6.	Regulation	Solar panels regulated by computer power board
7.6.7.	Security	Solar panel array bolted to message sign frame with security screws and special security nut. Tool for security screws mounted inside battery box.

8. DIMENSIONS & WEIGHT

8.1. Dimensions *inches (cm)*

Travel position

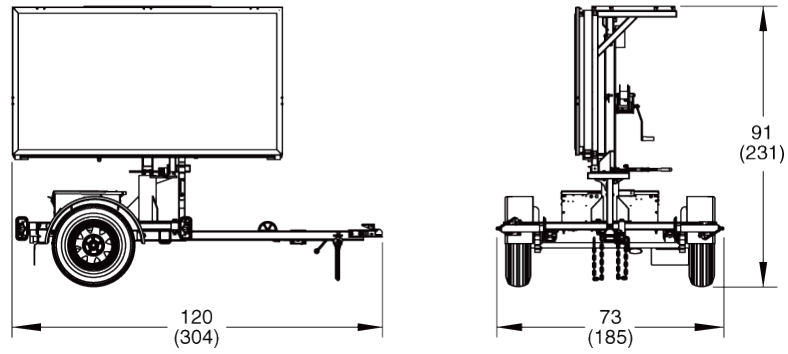

Deployed

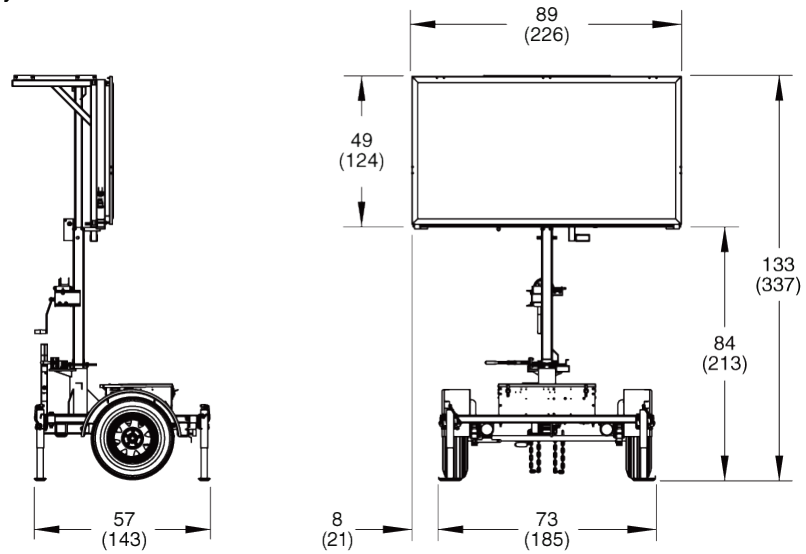

8.2. Weight **Approx. 1620 lbs. (735kg)**

9. OPTIONS AND OPTIONAL EQUIPMENT

- 9.1. Tow hitch** Combo-hitch for pintle hook and 2-inch ball hitch
Heavy-duty lunette ring, 2½" ID x 1⅝" cross-section
- 9.2. Tow-vehicle plug** Many types of plugs available, prewired at the factory; contact factory for details
- 9.3. Power**
- 9.3.1. Additional batteries For geographic locations with less solar charging potential or colder weather, and for applications that require year-round charging, add batteries for greater capacity
- Options One additional 4D AGM batteries, 200Ah additional capacity
Two additional 4D AGM batteries, 400Ah additional capacity
Four additional 4D AGM batteries, 800Ah additional capacity
- 9.3.2. 6-volt batteries Replace standard batteries with lighter-weight 6Vdc batteries, wired in parallel and series for a 12-volt system
- Options Six Group 24 AGM 6Vdc batteries, 645Ah total capacity
Eight Group 24 AGM 6Vdc batteries, 860Ah total capacity
- Weight Approx. 60 lbs. (26kg) each
- 9.3.3. Remote charger When required for added battery charging capacity, replace standard remote charger with 75-amp charger
- 9.4. Secure battery box**
- 9.4.1. Battery box High-security battery box features heavy-gauge steel lid, hidden hinges, and heavy-duty hidden-shackle padlocks. Replaces standard battery box.
- 9.4.2. Crossbar Optional heavy-duty, lockable crossbar fits over top of secure battery box, preventing lid from opening
- 9.5. Taillights**
- 9.5.1. Dual sealed-bulb Dual sealed-bulb taillights replace standard sealed-bulb taillights
Requires SAE J560 7-pole round-pin trailer plug to replace standard trailer plug
- 9.5.2. Single LED Single LED taillights replace standard sealed-bulb taillights
- 9.5.3. Dual LED Dual LED taillights replace standard sealed-bulb taillights
Requires SAE J560 7-pole round-pin trailer plug to replace standard trailer plug
- 9.6. Reflective tape** Reflective red-and-white conspicuity tape across rear trailer frame for increased visibility
- 9.7. Finish color** Specify power-coat color and, if applicable, color scheme

9.8. Radar-based speed monitoring system

- 9.8.1. Description Approach-only radar senses the largest moving mass moving toward it. The message sign conveys a user-selected message to the motorist.
- 9.8.2. Band K-band transmitter
- 9.8.3. Location Radar head located on the bottom of the message sign display cabinet, just off-center, for maximum effectiveness regardless of which side of the road the trailer is being used
- 9.8.4. Enclosure Radar head is sealed to withstand the elements, while an aluminum cover goes over the head unit for impact resistance
- 9.8.5. Standards compliance FCC approved
CE compliant
- 9.8.6. Distance range 1000 ft. @ 5 to 85 mph (305m @ 8 to 137km/h)
- 9.8.7. Speed range 5 to 99 mph (8 to 222km/h)
- 9.8.8. Accuracy ±1 mph from 5 to 40 mph, ±2 mph from 40 to 100 mph
(±1.6km/h from 8 to 64km/h, ±3.2 from 64 to 161km/h)
- 9.8.9. Frequency 24.150 ± 0.05 GHz
- 9.8.10. Electrical protection Fused and reverse-polarity protected
- 9.8.11. Calibration Radar is factory calibrated; a tuning fork for verifying radar is operating correctly is attached inside the control cabinet door; when struck and held in front of the radar head, the tuning fork vibrations simulate 55 mph

9.9. Cellular modem package

- 9.9.1. Purpose The remote communications package enables the message sign to be controlled from remote locations away from the message sign, using an Internet-connected computer, tablet, or smartphone. Includes all of the items described below.
- 9.9.2. Remote NTCIP central control software

Description	Easy-to-use program connects a computer to an individual message sign via an Internet connection. Used for changing messages, checking on trailer health status (such as battery voltages), viewing GPS locations, and setting message schedules.
System requirements	Microsoft® Windows® (most versions) .NET framework Internet connection
- 9.9.3. Web-based remote control

Description	Using a standard Web browser, allows connection to an individual message sign without software. Ideal for smartphone users.
-------------	-----------------------------------------------------------------------------------------------------------------------------

	System requirements	<p>Modern standards-compliant Web browser (such as Mozilla® Firefox®, Microsoft Internet Explorer® 7, Opera™, or Safari®) with JavaScript enabled</p> <p>A platform that supports one of these browsers (smartphone, laptop computer, or desktop computer)</p> <p>Internet connection</p>
9.9.4. Wanco Fleet Manager	Description	Web-based application for managing even the most diverse message sign fleets
	Features	<p>Add or remove equipment to groups for quick access, ideal for managing contractor rentals or entire projects all at once</p> <p>Map GPS locations of entire message sign fleet simultaneously</p> <p>Record vital information from signs, such as message changed by user and date, battery and solar voltages, and equipment alarms</p> <p>Mass broadcast capability, perfect for Amber Alerts and emergencies</p>
	System requirements	<p>Modern standards-compliant Web browser (such as Mozilla Firefox, Microsoft Internet Explorer 7, Opera, or Safari)</p> <p>A platform that supports one of these browsers (laptop or desktop computer)</p> <p>Internet connection</p>
9.9.5. Cellular plans	User provided	User obtains cellular data plan from, and makes monthly payments to, service provider. Wanco programs modem according to user-provided specifications at time of modem purchase. Wanco tests modem setup.
	Wanco cellular service	Wanco provides Verizon® cellular service without activation charges, monthly payments, or overage charges. User makes a single payment annually to Wanco. For increased security, Wanco hosts the service on a virtual private network (VPN).
9.9.6. Modem	Compact industrial cellular gateway	
	Optional modems available; contact factory for details	
	Carriers	Approved for use on Verizon, AT&T®, Sprint®, Rogers™, Bell™, and Telus®
	Security	Latest levels in security, IP sec, SSL, and GRE VPN client
	Power	<p>Input voltages range: 7 to 28Vdc</p> <p>Typical power consumption: 250mA @ 12Vdc</p>
	Operating temperature	-22 to 158°F (-30 to 70°C)

9.9.7. Antenna	Low-profile dual-function GSM/GPS
	Location Installed at highest point on message sign
	GPS L1 antenna 1575.42 ±3 MHz center frequency <15mA @ 3 to 5V
	GSM antenna Dual band, 824 to 896 MHz and 1710 to 1990 MHz
	Connectors SMA connectors for GSM and GPS antennas

9.10. Traffic Data Classifier System

9.10.1. Design	Radar-based, nonintrusive, does not require loops or hoses, no disturbance of traffic flow during installation or use
9.10.2. Direction	Registers both approaching and receding vehicles
9.10.3. Traffic lanes	Most effective for 2-lane roads
9.10.4. Traffic count	Can record data for more than 1 million vehicles in internal memory
9.10.5. Data format	Speed, date, time, direction, length for each vehicle
9.10.6. Units	English or metric
9.10.7. Time stamp	Yr,Mo,Dy,Hr,Min,Sec.
9.10.8. Speed range	5 to 138 mph (8 to 222 km/h)
9.10.9. Sensor	Microwave K-band 24.125 GHz
9.10.10. Power	Uses radar-speed sign power supply
9.10.11. Power output	20 dbm (EIRP)
9.10.12. Current	110 mA
9.10.13. Temperature	Operating limits: -40 to 185 °F (-40 to 85 °C)
9.10.14. Internal memory	1MB (1,048,576 bytes)
9.10.15. Baud rate	9600, 8 bit, no parity
9.10.16. Calibration	Self-calibrating
9.10.17. Installation	Automatically positioned horizontally when trailer is level; adjustable bracket allows user to point toward traffic at a 45-degree angle

9.11. RemoteUI control software

- | | |
|-----------------------------|-----------------------------------------------------------------------------------------------------------------------------------------------------------------------------------------------------------------|
| 9.11.1. Description | The Wanco RemoteUI program allows operators to control the message board using a laptop computer or touchscreen device. The computer must be connected to the message sign; wireless access is not recommended. |
| 9.11.2. Fleet limits | Connects to one sign at a time; maximum number of signs is unlimited |
| 9.11.3. Security | Multi-level password protection |
| 9.11.4. System requirements | Microsoft Windows (most versions) or Unix® operating system |

EXHIBIT A: MESSAGE FONTS



Font 1

5 x 7 pixels
7.68" x 10.98" (195 x 279mm)
Standard fixed-width font with lower-case letters
3 lines of 8 characters, maximum



Font 2

5 x 8 pixels
7.68" x 12.64" (195 x 321mm)
Tall fixed-width font with lower-case letters
3 lines of 6 characters, maximum



Font 3

6 x 9 pixels
9.33" x 14.29" (237 x 363mm)
Bold proportional font with 4x9-pixel capitals for lower-case letters
2 lines of 7 characters, typical



Font 4

6 x 11 pixels
9.33" x 17.60" (237 x 447mm)
Bold proportional font with lower-case letters and accented characters
2 lines of 7 characters, typical



Font 5

6 x 11 pixels
9.33" x 17.60" (237 x 447mm)
Bold proportional font with lower-case letters, accented characters, and increased spacing
2 lines of 6 characters, typical



Font 6

5 x 12 pixels
7.68" x 19.25" (195 x 489mm)
Tall fixed-width font with 5x8-pixel capitals for lower-case letters
1 line of 8 characters, maximum





Font 7

7 x 12 pixels

10.98" x 19.25" (279 x 489mm)



Bold fixed-width font with 6x8-pixel capitals for lower-case letters

1 line of 6 characters, maximum



Font 8

7 x 23 pixels

10.98" x 37.44" (279 x 951mm)



Large fixed-width font with 6x14-pixel capitals for lower-case letters

1 line of 6 characters, maximum



Font 9

11 x 23 pixels

17.60" x 37.44" (447 x 951mm)

Large bold fixed-width font, capitals only (no lower-case letters)

1 line of 4 characters, maximum



Font 10

4 x 5 pixels

6.02" x 7.68" (153 x 195mm)

Mini proportional font with limited lower-case

4 lines of 10 characters, typical



Font 11

7 x 10 pixels

10.98" x 15.95" (279 x 405mm)

Large fixed-width font, capitals only (no lower-case letters)

2 lines of 5 characters, maximum



Font 12

9 x 14 pixels

14.29" x 22.56" (363 x 573mm)

Large bold fixed-width font, capitals only (no lower-case letters)

1 line of 4 characters, maximum

EXHIBIT B: ARROW BOARD FUNCTIONS

Flashing patterns



Flashing left or right arrow



Flashing double arrow



Flashing four-corner warning



Flashing caution-bar warning

Sequential patterns



Sequencing left or right arrow



Sequencing left or right stem arrow



Sequencing left or right chevron arrows



Alternating diamonds